

PRODUCT NEWS

## Photo IC as a light sensor with human eye sensitivity

ALPHA-ONE offers Photo IC: AC-series. Spectral response close to human eye sensitivity can be obtained without any visual compensated filters.

### ◆ Applications

- ◇ Cameras
- ◇ Light Switching
- ◇ Light level measurements



### ◆ Reference Characteristics

#### AC-419 [Side view Type]

Feature: The output voltage is stable even though the ambient temperature is changed.

Parameter	Symbol	Value	Unit
Supply Voltage Range	$V_{CC}$	2.9 ~ 5.0	V
Supply Current	$I_{CC}$	Max. 670	$\mu A$
Operating Temperature	$T_{OPR}$	-10 ~ 60	$^{\circ}C$
Input Light Range	$I_{IN}$	0.03 ~ 20000	$lx$
Peak-wavelength	$\lambda_P$	Typ. 550	nm
Output Volgate	$V_{OUT}$	130	mV/Ev
Response Time	$T_r / T_f$	Max. 100	ms
Process		Bi-CMOS	

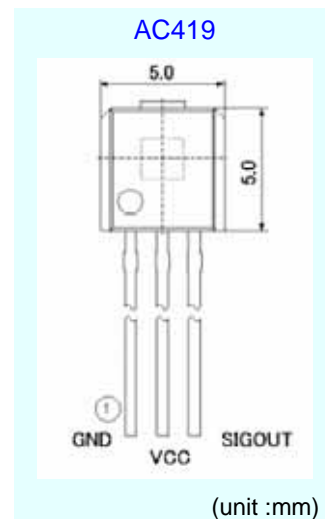

### Output voltage vs. Luminosity

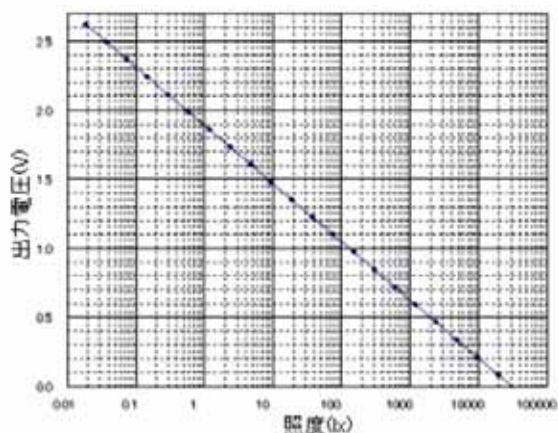

### Spectral Sensitivity

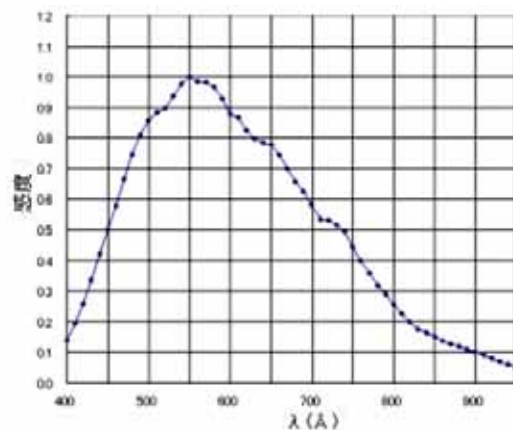

### AC-450 [Top view Type]

Feature: It can be easily replaced from  $\phi 5\text{mm}$  CdS Photoconductive Cells since the shape resembles them.  
It has an excellent linearity from 0lx to 200lx and is suitable for indoor application like TV and cell phones.

(unless specified,  $T_a=25^\circ\text{C}$ ,  $V_{DD}=5\text{V}$ ,  $R_{SS}=10\text{k}\Omega$ )

Parameter	Symbol	Value	Unit	Condition
Peak sensitivity wavelength	$\lambda_p$	520	nm	
Light Current	L1	10	$\mu\text{A}$	$E_V = 10\text{ lx}$
	L2	100		$E_V = 100\text{ lx}$
	L3	200		$E_V = 200\text{ lx}$
Dark Current	$I_{DD}$	4	nA	$E_V = 0\text{ lx}$
Switch Time	Rise time	8.5	mS	$V_{DD}=5\text{V}$ , $R_{SS}=10\text{k}\Omega$
	Fall time	8.5		

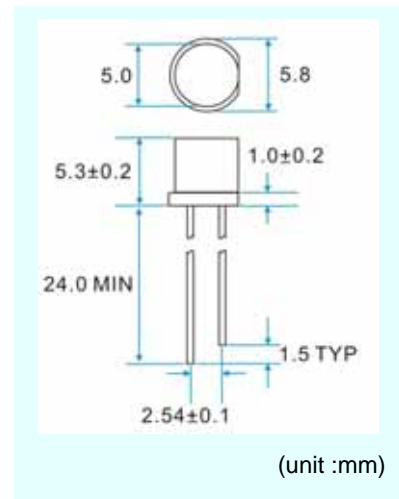

\* Tolerances for light current will be about  $\pm 50\%$ .

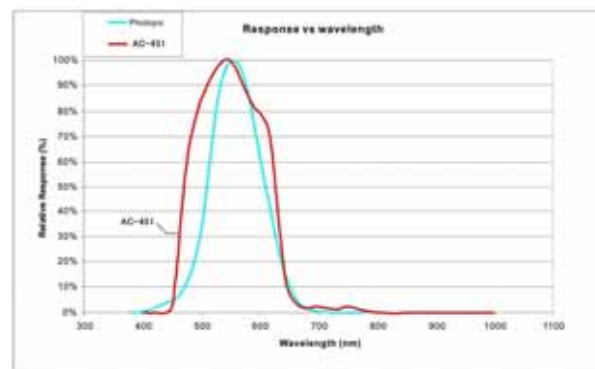
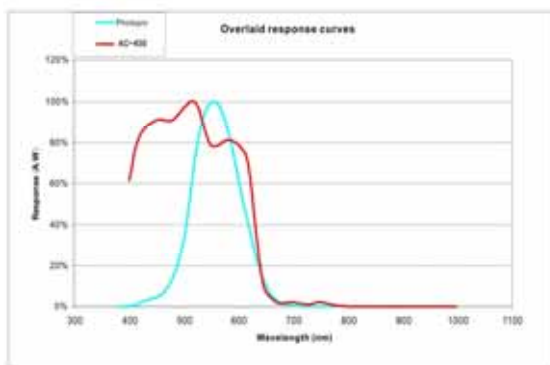

### AC-451 [Top view Type]

Feature: It has an excellent linearity upto 6000lux and does not have a sensitivity against infrared wavelength. Then, it is suitable for outdoor applications like Infrared cameras.

(unless specified,  $T_a=25^\circ\text{C}$ ,  $V_{DD}=5\text{V}$ ,  $R_{SS}=10\text{k}\Omega$ )

Parameter	Symbol	Min	Typ	Max	Unit	Condition
Peak sensitivity wavelength	$\lambda_p$		520		nm	
Infrared response			1	5	%of peak	900nm
Min. operational voltage	$V_{DD}-V_{SS}$		2.5		V	$I_{SS}=250\ \mu\text{A}$
			1.5			$I_{SS}=50\ \mu\text{A}$
Light Current	L1	150	300	450	$\mu\text{A}$	$E_V = 2000\text{ lx}$
	L2	75	150	225		$E_V = 1000\text{ lx}$
	L3	7.5	15	22.5		$E_V = 100\text{ lx}$
Dark Current	D1		<1		nA	0 lx, $T_a=25^\circ\text{C}$
	D2		170			0 lx, $T_a=85^\circ\text{C}$
Gain Linearity		-10		10	%	
Useable light range		1		6000	Lux	$R_{SS}$ & $V_{DD}$ dependant

With a lower  $R_{SS}$  resistance, the linear light response range can be greatly increased – up to 6000 lx.

**AC-455** [Top view Type]

Feature: It is low cost version of AC-450.

(unless specified,  $T_a=25^{\circ}\text{C}$ ,  $V_{DD}=5\text{V}$ ,  $R_{SS}=10\text{k}\Omega$ )

Parameter	Symbol	Value	Unit	Condition
Peak sensitivity wavelength	$\lambda_P$	550	nm	
Light Current	L1	40	$\mu\text{A}$	$E_V = 10\text{ lx}$
	L2	400		$E_V = 100\text{ lx}$
Dark Current	$I_{DD}$	Max. 10	nA	$E_V = 0\text{ lx}$
Switch Time	Rise time	8.5	mS	$V_{DD}=5\text{V}$ , $R_{SS}=10\text{k}\Omega$
	Fall time	8.5		

\* Tolerances for light current will be about  $\pm 50\%$ .

---

**If you have any questions, please make contact with us ASAP!**

✉ [info@alpha1-eg.com](mailto:info@alpha1-eg.com)